

Class 800 Forged Stainless Steel Swing Check Valve



FIG.# 4E-38F1610S/T/ST

Class 800, Swing Type, Bolted Bonnet, ASTM A182/ F316L
316L Body and Bonnet

Available in Socket Weld, Threaded and SW x Thrd connections
Both NACE MR- 0175 Compliance and None NACE are in stock

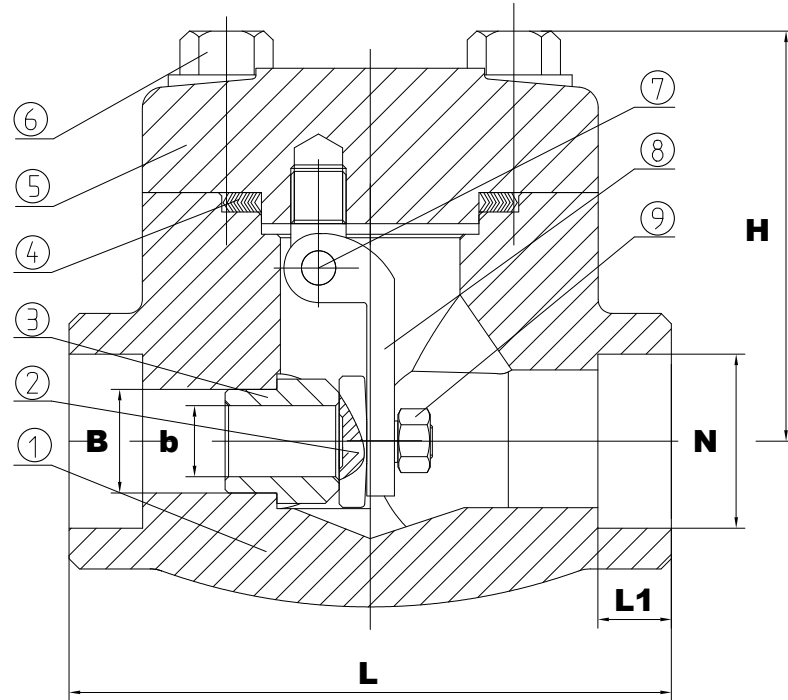

CLASS		800	
Test	Shell	21.4	MPa
	Seat	15.4	
Temperature: - 29°C (- 20°F) ~ 300°C (572°F)			
Medium: Water, Oil & Gas			

STANDARDS COMPLIANCE:

Design and Manufacture	API 602
Face to Face Dimensions	MFG'S
End Connection	Socket Weld Ends to ASME B16.11 Screwed Ends (NPT) to ASME B1.20.1 Butt Welding Edns to ASME B16.25
Pressure- Temperature	ANSI B16.34
Test & Inspect	API 598

MATERIAL LIST

No.	Part Name	Material
1.	Body	ASTM A182 F316L
2.	Disc	ASTM A182 F316L
3.	Seat	ASTM A182 F316L
4.	Gasket	SS 316 + Flexible Graphite
5.	Bonnet	ASTM A182 F316L
6.	Bolt	A193 B8M
7.	Pin	A276 316L
8.	Hinge	SS316L
9.	Nut	A194 8M



NOTE:

- Due to the continuous development of our products, specifications subject to change without notice.
- In Dimension & Weight (SW) figures are for Socket Weld Valves only.
- Please specify whether the product is NACE compliance when placing your order, otherwise 4E will ship out products in accordance with our inventory.

DIMENSIONS & WEIGHT

SIZE	unit	1/2"	3/4"	1"	1-1/4"	1-1/2"	2"
L	inch	3.11	3.62	4.37	4.72	4.72	5.51
	mm	79	92	111	120	120	140
L1 (SW)	inch	0.39	0.51	0.51	0.51	0.51	0.63
	mm	10	13	13	13	13	16
NPT	inch	1/2"	3/4"	1"	1-1/4"	1-1/2"	2"
	mm	12.7	19.1	25.4	31.8	38.1	50.8
N (SW)	inch	0.86	1.07	1.33	1.68	1.92	2.41
	mm	21.8	27.2	33.9	42.7	48.8	61.2
b	inch	0.41	0.53	0.71	0.91	1.14	1.42
	mm	10.3	13.5	18	23	29	36
B	inch	0.59	0.67	0.87	1.10	1.37	1.65
	mm	15	17	22	28	35	42
H	inch	2.60	2.63	3.23	3.43	4.17	4.84
	mm	66	67	82	87	106	123
Weight	LBS.	3.40	3.70	6.32	8.49	12.35	15.43
	Kgs.	1.54	1.68	2.87	3.85	5.6	7



Class 800 Forged Stainless Steel Piston/Lift Check Valve

FIG.# 4E-58F1610S/T/ST

Class 800, Swing Type, Bolted Bonnet, ASTM A182/ F316L
 316L Body and Bonnet
 Available in Socket Weld, Threaded and SW x Thrd connections
 Both NACE MR- 0175 Compliance and None NACE are in stock

CLASS		800	
Test	Shell	21.4	MPa
	Seat	15.4	
Temperature: - 29°C (- 20°F) ~ 300°C (572°F)			
Medium: Water, Oil & Gas			
Cracking Pressure: 3 Bar			

STANDARDS COMPLIANCE:

Design and Manufacture	API 602
Face to Face Dimensions	MFG'S
End Connection	Socket Weld Ends to ASME B16.11 Screwed Ends (NPT) to ASME B1.20.1 Butt Welding Edns to ASME B16.25
Pressure- Temperature	ANSI B16.34
Test & Inspect	API 598

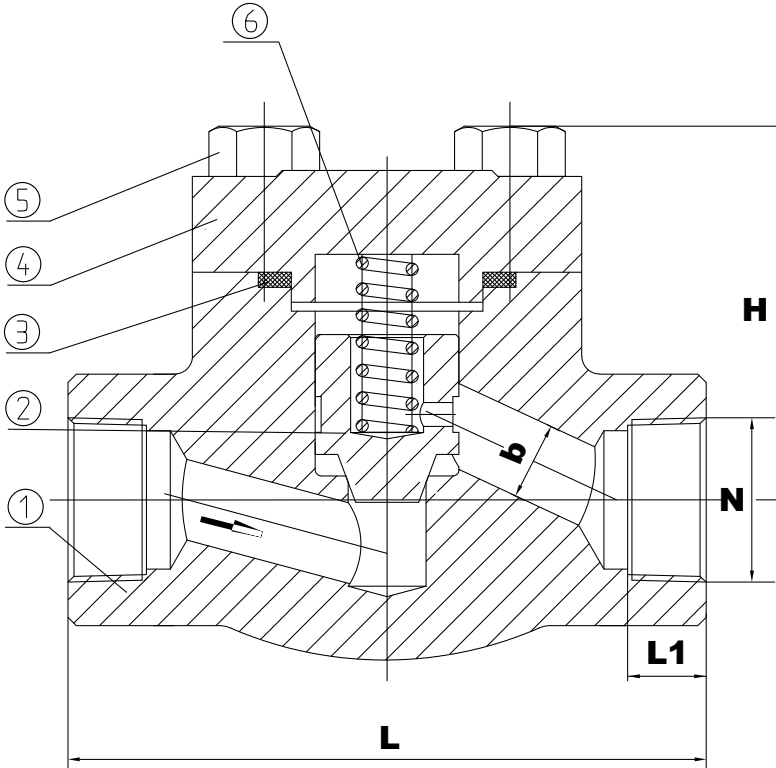

MATERIAL LIST

No.	Part Name	Material
1.	Body	ASTM A182 F316L
2.	Disc	ASTM A182 F316L
3.	Gasket	SS + Flexible Graphite
4.	Cover	ASTM A182 F316L
5.	Stud	A193 B8M
6.	Spring	SS316



NOTE:

1. Due to the continuous development of our products, specifications subject to change without notice.
2. In Dimension & Weight (SW) figures are for Socket Weld Valves only.
3. Please specify whether the product is NACE compliance when placing your order, otherwise 4E will ship out products in accordance with our inventory.

DIMENSIONS & WEIGHT

SIZE	unit	1/2"	3/4"	1"	1-1/4"	1-1/2"	2"
L	inch	3.11	3.62	4.37	4.72	5.98	6.77
	mm	79	92	111	120	152	172
L1 (SW)	inch	0.39	0.51	0.51	0.51	0.51	0.63
	mm	10	13	13	13	13	16
NPT	inch	1/2"	3/4"	1"	1-1/4"	1-1/2"	2"
	mm	12.7	19.1	25.4	31.8	38.1	50.8
N (SW)	inch	0.86	1.07	1.33	1.68	1.92	2.41
	mm	21.8	27.2	33.9	42.7	48.8	61.2
b	inch	0.39	0.51	0.67	0.87	1.06	1.30
	mm	10	13	17	22	27	33
H	inch	2.44	2.48	3.07	3.23	4.02	4.72
	mm	62	63	78	82	102	120
Weight	LBS.	3.40	3.70	6.32	8.49	13.89	17.74
	Kgs.	1.54	1.68	2.87	3.85	6.3	8.05